

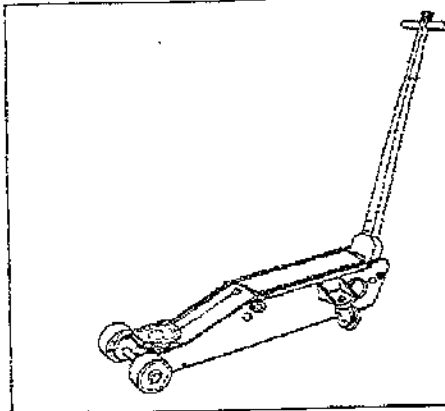

# MODEL 93660 HYDRAULIC SERVICE JACK (10 TON)

SERIES: "E"

## OWNERS MANUAL



### SPECIFICATIONS

<b>RATED LIFTING CAPACITY</b>	<b>20,000 lbs</b>
LOW PICK UP HEIGHT	5-7/8"
HIGH LIFTING POINT	25"
LIFT CAP SIZE (SQUARE)	7-1/2"
CHASSIS LENGTH	53-3/8"
CHASSIS HEIGHT	9-3/4"
HANDLE LENGTH	50"
FRONT WHEEL DIAMETER	6"
CASTER WHEEL DIAMETER	4"
SHIPPING WEIGHT	410 lbs

### DESCRIPTION

Model 93660 jack is designed for shops where heavy equipment is serviced. The jack provides the following features:

- Dual action pump raises the jack quickly to contact a vehicle lift surface.
- Long chassis and handle reaches under long, low vehicles.
- Handle adjusts to three pumping positions for operator convenience and low clearance vehicles.
- Automatic overload protection prevents overloading and exceeding the jack rated lifting capacity.

### OWNER/OPERATOR RESPONSIBILITY

It is the owner/operator responsibility to properly use and maintain this equipment.

The instructions and warning contained in this manual shall be read and understood by the owner/operator prior to operating this equipment.

If an owner/operator does not understand English, the contents of this manual shall be explained in the owner/operator native language to assure the owner/operator comprehends.

It is the owners/operators responsibility to maintain the legibility of all warning and instruction labels.

The owner/operator shall retain this manual for future reference to important warnings, operating and maintenance instructions.



### ⚠ WARNING

**FAILURE TO FOLLOW WARNINGS MAY RESULT IN INJURY OR PROPERTY DAMAGE**  
**—USE VEHICLE STANDS— AFTER LIFTING**

- Use only as a lifting device.
- Center the load on the saddle.
- Lift only at locations suggested by the vehicle manufacturer.
- Use jack and vehicle stand saddle lugs for gripping.
- Do not exceed rated capacity.
- Use on hard level surfaces.
- Set parking brakes and chock wheels.
- Do not crawl under vehicle when placing stands.
- Lower the vehicle slowly.
- For safety, follow instructions in Owner's Manual.



One Lincoln Way  
St. Louis, Missouri 63120-1578  
(314) 279-4200  
Customer Service: (314) 678-4300

Copyright 1989  
Printed in U.S.A.

Section - **W1**  
Page - **8G**

**INSPECTION**

Prior to operation or maintenance a visual jack inspection shall be made. Check for bent or worn chassis parts, hydraulic leaks, damaged, loose or missing parts.

Check jack operation by closing release valve and pumping jack handle. Make sure jack operates smoothly and is not binding or requires lubrication. If jack does not respond to pump action, refer to TROUBLESHOOTING and perform AIR PURGING procedure.

If jack is damaged, badly worn, or operates abnormally it shall be removed from service. Contact a factory authorized service center for repair.

If the jack has been subjected to an abnormal load or shock, the jack shall be inspected by a factory authorized service center.

An annual jack inspection is recommended to be performed by a factory authorized service center.

**OPERATION**

Jack operation is controlled by pumping the jack handle and opening and closing the release valve with the release knob located on the top of the jack handle. To raise the jack, firmly close the release valve by turning the release knob clockwise and pumping the jack handle. To lower the jack, open the release valve by turning the release knob counterclockwise.

The rate at which the jack raises is controlled automatically by the dual action pump. When the handle is first pumped, the pump will raise the jack quickly until the load is contacted. The pump then switches automatically to high pressure to raise the load.

The jack handle position may be changed by pulling out the release knob to disengage the lock and moving the handle to the desired position. Three handle positions are provided for operator convenience.

**RAISING A VEHICLE**

- A. Set vehicle parking brakes and block vehicle wheels.
- B. Open release valve by turning release knob counterclockwise and allow jack to fully retract.
- C. Position jack under desired vehicle lifting point suggested by manufacturer. Floor area in front of jack wheels must be free of obstructions to allow jack to move forward while lifting.
- D. Select the best handle position to operate the jack by pulling up on release knob.
- E. Firmly close release valve by turning release knob clockwise.
- F. The jack lift cap must contact the vehicle lift surface squarely and as close to center of lift cap as possible.
- G. Pump jack handle and raise vehicle to desire height. **DO NOT** lift vehicle any higher than is needed to make repairs.
- H. **DO NOT** crawl under vehicle while positioning vehicle stands.
- I. Slowly and carefully lower vehicle on to vehicle stands or other appropriate supports.

**LOWERING A VEHICLE**

- A. Make sure release valve is closed by firmly turning release knob clockwise.
- B. Pump jack handle and raise vehicle just enough to clear vehicle stands or support means.
- C. Remove vehicle stands or other support means from under vehicle. **DO NOT** crawl under vehicle when removing vehicle stands.
- D. Slowly turn release knob counterclockwise to open release valve and lower vehicle.

- E. When vehicle is fully lowered remove jack from under vehicle.

**MAINTENANCE****CHECKING HYDRAULIC OIL LEVEL**

Fill hydraulic reservoir as follows:

- A. Open release valve by turning release knob counterclockwise and allow jack to fully retract.
- B. Raise front end of the cover over hydraulic unit assembly to gain access to filler plug on top of the reservoir.
- C. Clean dirt from around filler plug and remove filler plug from hydraulic unit assembly.
- D. Fill hydraulic reservoir with clean hydraulic jack oil to a level that just covers the hydraulic cylinder visible through the filler hole. Do not overfill.

 **CAUTION**

**BRAKE OR TRANSMISSION FLUIDS WILL DAMAGE JACK SEALS.**

- E. Reinstall filler plug in hydraulic unit assembly. Hand tightening is usually adequate.
- F. Lower cover over hydraulic unit assembly and latch by pressing downward.

**LUBRICATION**

Lubricate jack as follows:

- A. Open release valve by turning release knob counterclockwise and allow jack to fully retract.
- B. Raise cover over hydraulic unit assembly by lifting the end opposite the handle.
- C. Apply oil to release mechanism universal joint, pump linkage and all moving joints at the low end of the handle.

- D. Apply chassis grease to bell crank ram pin and fulcrum pin grease fittings until pin is fully lubricated.
- E. Close release valve by turning release knob clockwise.
- F. Pump jack handle until jack is fully extended.
- G. Apply oil to all pin joints under lifting cap.
- H. Open release valve by turning release knob counterclockwise and allow jack to fully retract.
- I. Apply oil or chassis grease to wheels, caster swivel bearings, and the hydraulic unit union bushings until fully lubricated.
- J. If required, repeat steps C through I until jack operates and moves freely.
- K. Lower cover over hydraulic unit assembly and press down to latch.

## TROUBLESHOOTING

If the following procedures do not correct the problem, contact a factory authorized service center. When submitting a jack or equipment to be repaired, be sure to state the nature of the problem and indicate if a repair cost estimate is required.

### AIR PURGING

As with any hydraulic unit, the jack may occasionally become air bound due to being tipped over during shipment or handling. To purge air from jack hydraulic circuit, perform the following procedure:

- A. Open release valve by turning release knob on end of jack handle one full turn counterclockwise.
- B. Rapidly pump jack handle six or more full strokes to purge air from hydraulic circuit.
- C. Close release valve by turning release knob clockwise.

- D. Pump jack handle until jack is fully extended. Pump jack handle two or three more full strokes to activate the jacks overtravel limiting device.
- E. Open release valve by turning release knob counterclockwise and allow jack to retract quickly.
- F. Close release valve by turning release knob clockwise.
- G. Check pump action by pumping jack handle. If jack does not respond, repeat the above procedure several times until air is fully purged from the hydraulic system.

## COMMON PROBLEMS

### JACK FEELS SPONGY WHEN LIFTING VEHICLE.

- Air in hydraulic system. Refer to AIR PURGING procedure and purge air from system.

### JACK WILL NOT LIFT TO FULL HEIGHT.

- Oil level low. Refer to CHECKING HYDRAULIC OIL LEVEL procedure in maintenance section of this manual.

### JACK WILL NOT HOLD LOAD.

- Release valve not closed or not sealing. Internal repairs may be required.
- Dirt in hydraulic oil or pump ball valves not seating. Flush hydraulic circuit by closing release valve and pumping jack to maximum height. Open release valve and quickly lower jack by manually pushing on lift cap. Repeat if necessary. If this procedure does not correct the problem, internal repairs are required.

### LIFTING ARM WILL NOT LOWER PROPERLY.

- Broken return springs. Replace return springs.
- Lift arm bearings are binding. Refer to LUBRICATION procedure and lubricate lift arm.

- Hydraulic cylinder ram binding. Repair hydraulic cylinder assembly.
- Fulcrum pin, parallel link pin or bell crank pin or ram cross pin also bent or worn. Repair jack as required.

## LIMITED WARRANTY

Lincoln, A Pennair Company, warrants that jacks and related service equipment manufactured by it will be free from defects in material and workmanship during the one (1) year following the date of purchase. This warranty is extended to the original retailer purchaser only. If a jack or related service equipment proves to be defective during this warranty period, it will be repaired or replaced without charge. To obtain repair or replacement, it must be shipped, transportation charges prepaid, with proof of date of purchase, to a Lincoln authorized Warranty and Service Center, within the one (1) year following the date of purchase. This warranty does not apply to parts damaged from accident, overload, or abuse, nor does it apply to any equipment which has been altered or used with special attachments other than those recommended by Lincoln. No other express warranty applies to jacks and related service equipment manufactured by Lincoln.

ANY IMPLIED WARRANTIES applicable to jacks and related service equipment manufactured by Lincoln, INCLUDING THE WARRANTIES OF MERCHANTABILITY AND FITNESS FOR A PARTICULAR PURPOSE, WILL LAST ONLY FOR ONE (1) YEAR FROM THE DATE OF PURCHASE. SOME STATES DO NOT ALLOW LIMITATIONS ON HOW LONG AN IMPLIED WARRANTY LASTS SO THE ABOVE LIMITATION MAY NOT APPLY TO YOU.

In no event shall Lincoln be liable for incidental or consequential damages. The liability of Lincoln on any claim or damage arising out of the sale, resale, or use of a jack or related service equipment shall in no event exceed the purchase price. SOME STATES DO NOT ALLOW THE EXCLUSION OR LIMITATION OF INCIDENTAL OR CONSEQUENTIAL DAMAGES, SO THE ABOVE LIMITATION OR EXCLUSION MAY NOT APPLY TO YOU.

THIS WARRANTY GIVES YOU SPECIFIC LEGAL RIGHTS, AND YOU MAY ALSO HAVE OTHER RIGHTS WHICH VARY FROM STATE TO STATE.

### SERVICE PARTS

Lincoln provides Factory Authorized Service Centers that stock equipment and replacement parts. Contact Lincoln Customer Service, One Lincoln Way, St. Louis, MO 63120-1578, (314) 679-4300 for your nearest Service Center.

When ordering replacement parts, list: part number, description, model number, and series letter.

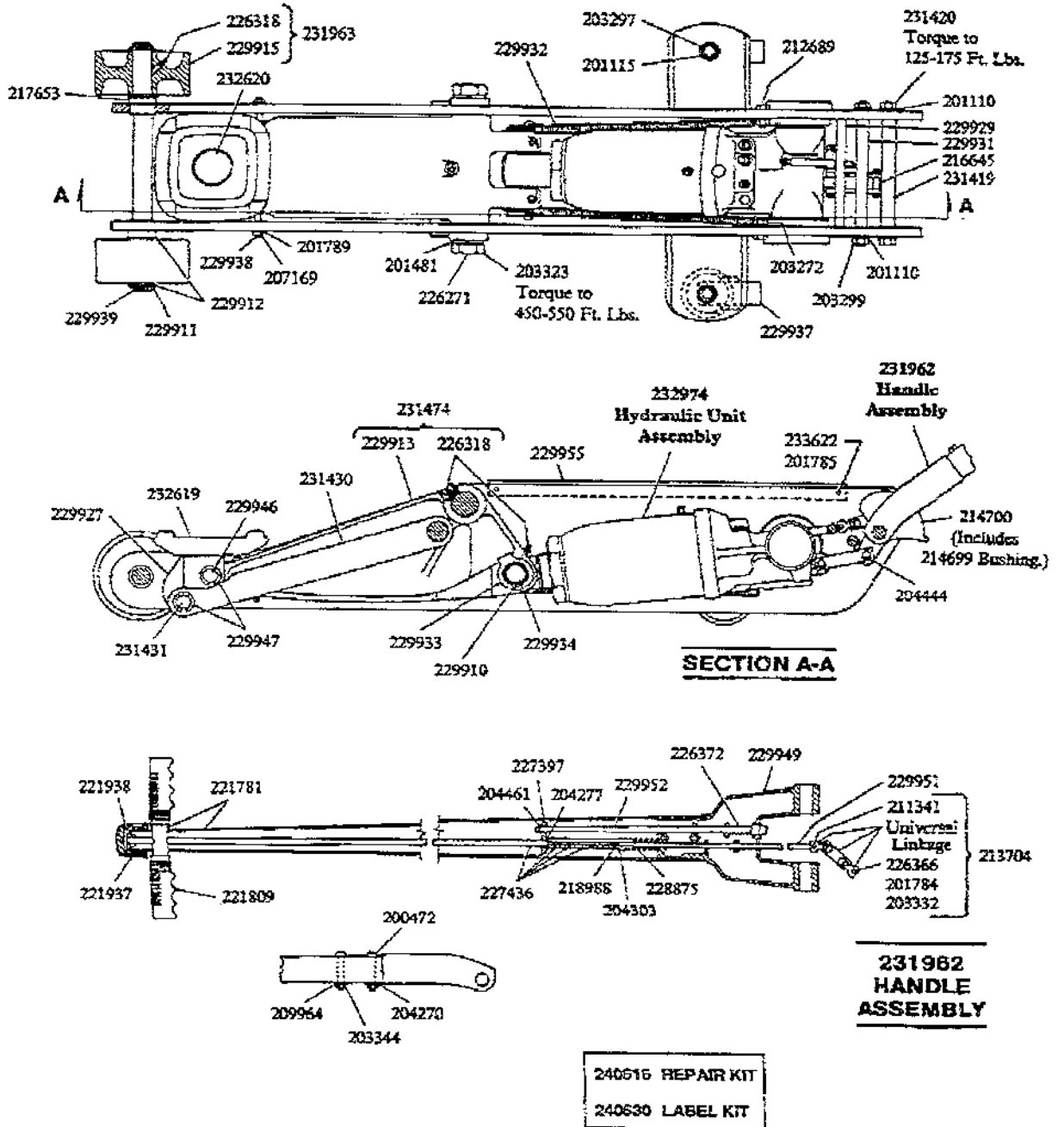

**SERVICE PARTS (CONT)**

PART	QTY	DESCRIPTION	PART	QTY	DESCRIPTION
200003	1	Gasket	226331	1	Spring
200472	2	Bolt	226353	1●	Spring
201110	4	Lockwasher	226366	1	Bolt
201115	2	Lockwasher	226372	1	Plunger spring
201461	2	Lockwasher	227397	1	Link
201733	1	Expansion plug	227436	1	Turning rod assembly
201764	1	Lockwasher	229875	1	Spring
201785	4	Lockwasher	229887	1●	O-ring
201789	2	Lockwasher	229888	1●	O-ring
203198	1●	Ball	229889	1●	O-ring
203199	1●	Ball	229896	1	Ram & cylinder assembly
203200	1●	Ball	229897	1	Ram
203201	1●	Ball	229898	1	Cylinder
203207	1●	Ball	229899	1●	U-cup packing
203272	2	Nut	229900	1●	Back-up washer
203297	2	Nut	229902	1	Cross pin
203299	2	Nut	229903	1	Pin
203323	2	Nut	229904	1	Plug
203332	1	Nut	229905	1	Plug
203344	2	Nut	229908	1	Spacer
204270	2	Washer	229909	1	Slotted tube
204277	1	Washer	229910	2	Retaining ring
204301	1	Washer	229911	2	Retaining ring
204303	1	Washer	229912	4	Washer
204372	1	Washer	229913	1	Bell crank
204444	4	Cotter pin	229915	2	Front wheel
204461	1	Cotter pin	229927	1	Cap housing
204842	1●	Gasket	229929	1	Bearing
207169	2	Nut	229931	1	Bumper pin
209964	2	Lockwasher	229932	2	Spring
210225	1	Spacer	229933	2	Plate
210311	3	Pipe plug	229934	1	Pin
210411	1●	Washer	229937	2	Caster
211341	1	Rivet	229938	1	Pin
212227	1	Release Valve	229939	1	Front axle
212689	2	Bolt	229946	1	Pin
213152	2●	Packing ring	229947	4	Retaining ring
213171	2●	Packing ring	229949	1	Handle socket
213704	1	Universal linkage assembly	229951	1	Extension rod
214555	1●	O-ring	229952	1	Plunger assembly
214699	1	Bushing	229955	1	Cover
214700	1	Handle segment & bushing	229956	1	Heel plate
216645	1	Pin	231316	1	Filter plug & gasket assy.
216646	1	Pin	231419	1	Fulcrum pin
217653	2	Roll pin	231420	2	Bolt
218988	1	Roll pin	231430	2	Parallel link
218991	1	Roll pin	231431	1	Pin
220769	1	Cross pin	231474	1	Bell crank & fittings
221739	1	Poppet	231838	1	Filter plug & vent valve
221742	1	Ball stop plug	231717	1	Base
221770	1	Speed pump	231718	1	Oil tank
221771	1●	Back-up washer	231945	1	Ram assembly
221772	1	Quad ring	231962	1	Handle assembly
221791	1	Handle & cross bar	231963	2	Front wheel assembly
221809	2	Handle grip	232619	1	Lifting cap
221937	1	Release knob	232620	1	Swivel pin
221938	1	Roll pin	232969	1●	Back-up washer
222095	1	Release stem assembly	232969	1●	U-cup packing
222098	1	Speed pump assembly	232970	1	Pressure pump
222201	1●	Spring	232971	1	Pressure pump & gland packing assy.
222257	1	Plug	232974	1	Hydraulic unit assembly
222533	2●	Screen	233622	4	Screw
223166	1●	Screen	233917	1	Plastic spring
226271	1	Fulcrum pin	233921	1	Release stem
226314	1	Gland nut	240630	1	Label kit
226318	5	Grease fitting	241482	1	Tank nut
226325	2	Pump link	241483	1●	Seal
226326	1	Gland nut			

● Included In 240516 Repair Kit