

OBSOLETE



# MODEL "X-10"

## HYDRAULIC JACK REPAIR PARTS LIST

### UNIT ASSEMBLY

ITEM NO.	PART NO.	DESCRIPTION	ITEM NO.	PART NO.	DESCRIPTION
1	24385	Ram Packing Nut	27		3/16 Ball
1A	*	Ram Packing	28	8435	Unit Body <i>NEW #82102</i>
1B	*	Ram Packing	29	9750	Alemite Drive Fitting
2	24335	End Nut	30	*	Packing—H.S.
3	8445	Reservoir Tube	31	18110	Packing Nut—H.S.
4	5115	Air Vent Assembly	32	18020	H.S. Piston—1 1/2 Diameter
	5190	Ram Assembly	33	9285	Pin w/2 Pin Rings
5	8290	Ram w/24425 Piston	34	12415	Pin Rings
6	24425	Piston	35	25965	3/16 x 1" Roll Pin
7	*	Cup	36	5080	Release Rod Ext. Assembly
8	24390	Retainer	37	17835	5/32 x 1 1/2 Pin
9	8440	Cylinder	38	23675	Release Gear w/Pin
10	8450	Seal for Cylinder	39	26855	1/4-18 Hex Jam Nut
11	25935	1/8-27 NPTF Pipe Plug	40	24290	Link—L.P.
12	80007	Filler Screw w/Washer	41	*	"O" Ring
13	17890	Valve	42	19575	Release Screw
14	18035	Spring	43	8375	Washer
15	17785	Washer	44	19585	Release Screw Nut
16	17960	Plug w/Washer	45	19505	Yoke
17	11855	Plug	46	14840	Roll Pin
18	*	Seal	47	16020	Spring
19	*	Spring	48	*	Packing H.P.
20	*	Spring	49	18125	Packing Nut H.P.
21	17520	Adjusting Screw only	50	18065	H.P. Piston—1 1/8 Diameter
22	*	3/8 Ball	51	24295	Link H.P.
23	*	Spring	52	17465	Pin w/2 Clips
24	*	Spring	53	16810	Clip
25	*	Spring Cap	54	7345	Seal
26	*	1/4 Ball	55	3580	Plug

@ ORDER KIT NO. 80753

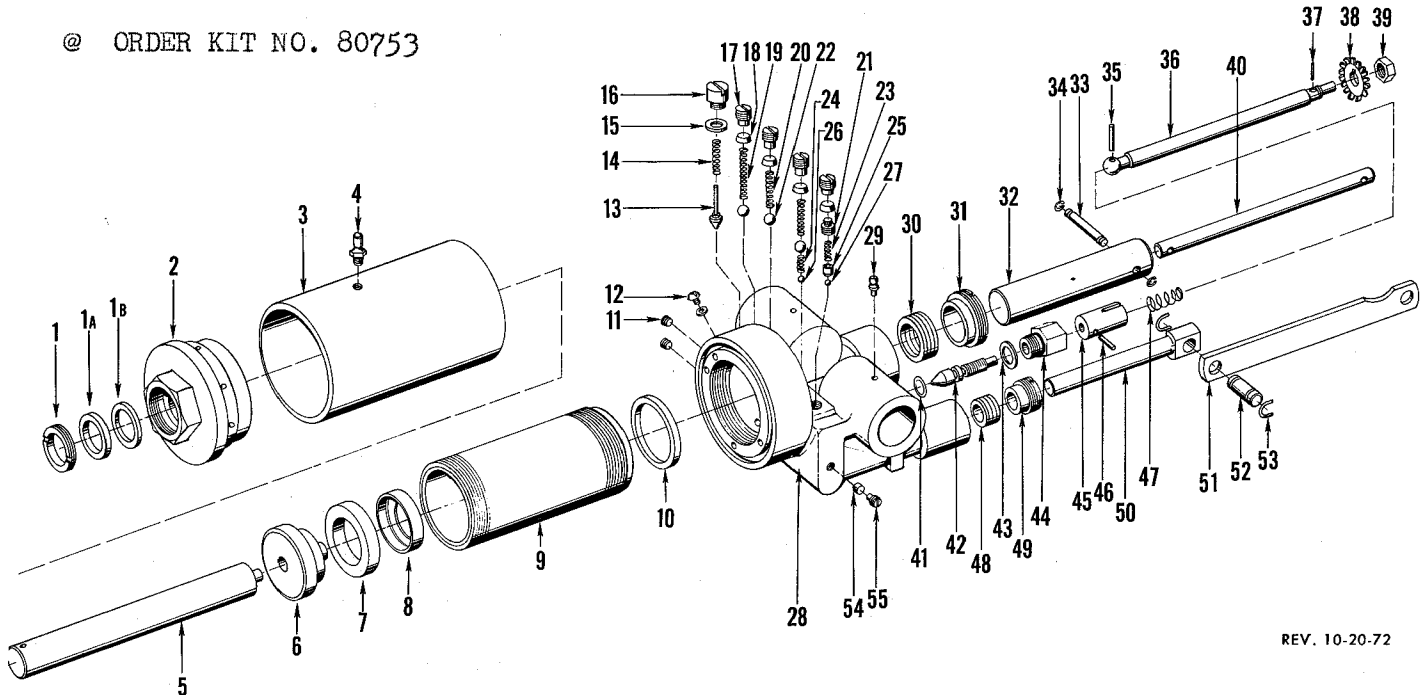

REV. 10-20-72

Order parts from the nearest Hein-Werner Official Service Station. Always state both model and serial number.

USE ONLY GENUINE HEIN-WERNER HYDRAULIC JACK OIL IN ANY HEIN-WERNER JACK

HEIN-WERNER CORPORATION

PRINTED IN U.S.A.

## CHASSIS ASSEMBLY FOR MODEL "X-10"

ITEM NO	PART NO.	DESCRIPTION	ITEM NO	PART NO.	DESCRIPTION
1	8295	Stud—Saddle	30	17670	Snap Rings
2	8430	Saddle	31	24355	L.H. Side Bar only
3	24280	Pin	32	2180	3/8 I.D. Shakeproof Washer
4	24380	Saddle Holder	33	26730	5/8-18 Hex Jam Nut 3/8" thick
5	14850	Roll Pin	34	2490	3/4 I.D. Shakeproof Washer
6	24360	Lift Arm w/Grease Fittings	35	26110	3/4-16 Hex Jam Nut 3/8" thick
7	24345	Connector Pin	36	2520	Shakeproof Lock Washer
8	25781	Roll Pin	37	24370	1 3/4-16 Hex Jam Nut 3/4" thick
9	24325	Cover <b>65300</b>		5210	Caster Assembly
10	24285	Pin	38	24420	Caster Bracket
11	24350	R.H. Side Bar only w/Bushing	39	14960	Bearing
12	24365	Front Axle	40	16525	Hex Jam Nut
13	21005	Clamp	41	2156	1/2 I.D. Shakeproof Washer
14	17940	Spring—Pull Back	42	61319	1/2-13 x 1 3/4 Hex Hd. Cap Screws
15	24330	Tie Rod	43	19675	Thrust Bearings
16	14841	Roll Pin	44	21740	Bearing Races
17	8250	Parallel Link	45	24395	Caster Fork
18	24340	Parallel Link Stud	46	16810	Clip
19	24270	Arm Pivot Pin	47	24410	Axle
20	25335	1/2-13 Hex Jam Nuts	48	9750	Alemite Fitting
21	24310	Handle Stop	49	16385	Needle Bearings
22	24375	Tie Rod—Rear	50	17410	Caster Wheel
23	17825	Handle Bushing	51	24440	Snap Ring
24	20955	Rivet	52	24305	Unit Pivot Pin
25	24315	Front Axle Bushing	53	25275	No. 10 x 1 Stove Hd. Phillips Hd. Screw
26	15995	Bearing	54	2180	3/8 I.D. Shakeproof Washer
27	8395	Front Wheel	55	26730	5/8-18 Hex Jam Nut 3/8" thick
28	9750	Drive Fitting—Alemite	56	17975	Fork Pin—Set of 2
29	17755	Washer			

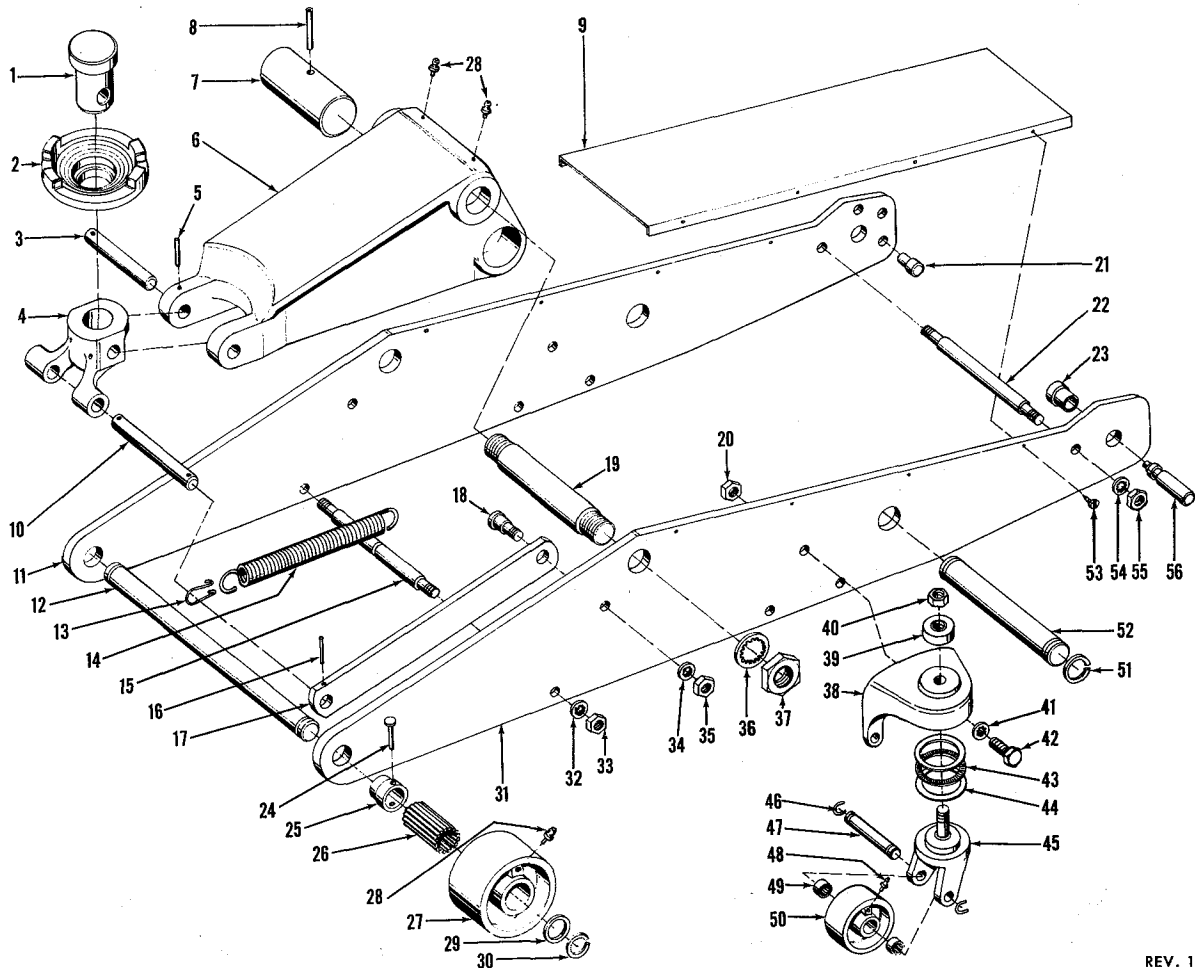

REV. 10-20-72

**USE ONLY GENUINE HEIN-WERNER HYDRAULIC JACK OIL IN ANY HEIN-WERNER JACK**

## HANDLE ASSEMBLY FOR MODEL "X-10"

ITEM NO	PART NO.	DESCRIPTION	ITEM NO	PART NO.	DESCRIPTION
	5243	Handle Assembly Complete	19A	26632	5/16 SAE Lockwasher
1	17985	Release Rod Hanger	20	25290	1/16 x 1/2 Cotter Pin
2	23715	3/32 x 1/2 x 1/16 Washer	21	18170	Quadrant Rod
3	9285	Pin w/2 Pin Rings	22	17810	Control Spring
4	12415	Pin Ring	23	5220	Handle Pipe w/Grip
5	18090	Quadrant Lock	24	23865	Washer
6	1745	Pin w/Rings	25	23625	Release Gear
7	12165	Pin Ring	26	18210	Release Rod
8	9750	Drive Fitting	27	17715	Control Knob
9	26470	5/16-18 x 3/8 Socket Hd. SS	28	17765	Spring
10	18140	Handle Fork	29	23865	Washer
11	55312	Name Plate	30	60153	10 x 1/4 Sheet Metal Screw
12	14945	No. 6 x 1/4 Type U Drive Screw	31	17430	Latch Plate
13	16810	Clip	32	17690	Catch Block
14	17465	Pump Link Pin w/Clip (Set of 2)	33	17735	Rivet
15	16810	Clip	34	17850	Grip
16	17450	Quadrant Lever	35	17920	Release Knob
17	18185	Screw	36	25480	1/4-28 Hex Jam Nut
18	2095	3/8-1220 Shakeproof Washer	37	55313	Caution Decal
19	26524	5/16-18 x 1/2 Rd. Hd. Screw			

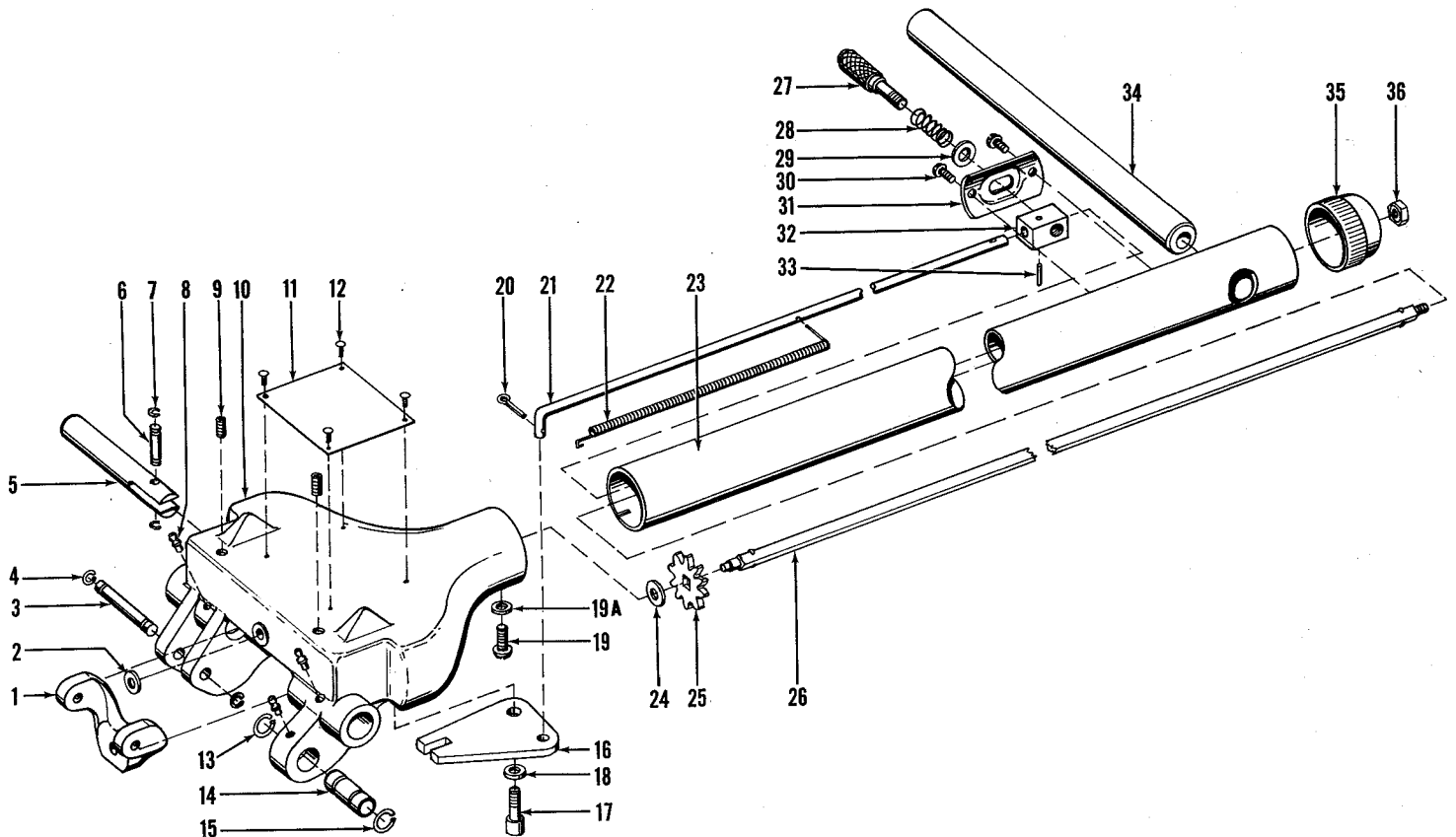

REV. 10-20-72

**USE NEW PART NUMBER ONLY WHEN ORDERING PARTS**

Order parts from the nearest Hein-Werner Official Service Station. Always state both model and serial number.

**USE ONLY GENUINE HEIN-WERNER HYDRAULIC JACK OIL IN ANY HEIN-WERNER JACK**

**HEIN-WERNER CORPORATION**

PRINTED IN U.S.A.

# General Care of Your X-10 Jack

A. Keep all moving parts of your jack well lubricated. As on any other piece of fine equipment, thorough lubrication of your jack will assure the best service.

B. Be sure the load is always centered on the saddle of your jack. Care in placement under a load prevents unnecessary strain on the jack and eliminates accidents caused by load tipping. Never work under a car held up by the jack only. Use Hein-Werner Safety Stands when it is necessary to get under a car or truck.

C. If you wish to remove the hydraulic unit from your jack, we recommend the following procedure. First, remove pins to disconnect both piston links from handle fork. Loosen Allen set screws holding handle pins and slide pins outward sufficiently to remove release hanger, release extension rod and tension spring from release collar. Remove screw and clip from end of ram, and take out unit.

D. To remove handle, first remove pins connecting both piston links to handle fork. Loosen the two Allen headless set screws in fork, freeing handle pins. Slide handle pins outward, remove release hanger, release extension rod and tension spring in release collar. Lift off handle.

## FILLING INSTRUCTIONS

If your jack does not raise to full height, it is probably low on oil. To refill, first remove the metal cover over the hydraulic unit. Be sure release valve is open and saddle down; then slowly remove the filler screw (12) from unit marked "Oil Level". Refill through filler hole until oil reaches top of oil level hole. Use only genuine Hein-Werner Hydraulic Jack Oil and be sure no dirt enters the unit. Never use hydraulic brake fluid which will ruin the packings and void the guarantee.

## HOW TO LOCATE AND REMEDY TROUBLE

### I. If Jack Will Not Lift or Raise Load

1. Be sure release valve is closed.
2. Sometimes hydraulic jacks become airborne. To correct, place front wheels on 3" block, open the release valve and pump handle eight full 90° strokes.
3. Your jack may be low on oil. See refilling instructions above.
4. The pump valves may be held open by a foreign particle. To flush valves, open release valve partially (about 1/2 turn of knob), and pump handle several strokes. If this does not clear them, remove the metal cover above the hydraulic unit. Be sure release valve is open. Then take out oil filler screw in reservoir to relieve any pressure in the unit. Refer to cross-sectional views on opposite page to identify pump valves. Remove pump valves for a thorough cleaning. Also inspect and clean seats. When replacing valves, insert a new No. 11520 Seal, using Seal Tool SS-12 for this purpose.
5. Pump Piston "V" packings may be worn. If so, oil will leak around one or both pistons. To inspect,

remove hydraulic unit as described in Instruction "C". Pull out pistons, keeping piston end of unit up so oil is not lost. Remove packing nuts and inspect "V" packings. If worn, dip new "V" packings in oil and insert hard ring with flat side down, followed by soft rings with grooved side down, being careful not to damage lips on machined threads. Turn down packing nuts sufficiently to hold "V" packings in position. Dip pistons in oil and insert. Tighten packing nuts to medium pressure.

6. The Release Valve may be held off its seat by a foreign particle. Flush by opening release valve and pumping handle several full strokes. If necessary to clean or inspect release valve, first remove hydraulic unit as described in Instruction "C". Place unit in vise with release valve end up and jaws of vise resting on unit casting. Take out oil level screw at top of unit casting to relieve any pressure in the unit. Turn out release valve by the large hex packing nut. Clean and inspect release seat and tip of release screw. A slight ring on tip of screw is not harmful. A nicked screw should be replaced.

### II. If Jack Lowers Under Load

1. The release valve and seat should be flushed and inspected as described in Instruction "6" of Section 1.
2. There may be dirt under the discharge ball in one of the pump valves. These should be flushed or cleaned as suggested in Instruction "4" of Section 1. When this condition exists, the handle raises as the saddle lowers.
3. The ram leather cup may be worn. This is likely only in jacks given very heavy service. To inspect this cup, first remove hydraulic unit from chassis (See Instruction "C"). Place unit in vise so ram end is up and jaws of vise rest on unit casting. Remove 24385 Ram Packing Nut. Remove 24335 End Nut Casting and pull out ram by hand. Inspect ram cup and install new one if worn. Dip new cup in oil before inserting ram into cylinder, taking care not to damage leather. When reassembling, place a thin coat of shellac on end of reservoir tube and firmly tighten down end nut. Inspect ram packings and replace if worn. Tighten down packing nut to medium pressure.

### III. If Jack Will Not Lift Full Ten Ton Capacity

1. Release screw may be worn. See instruction "6" of Section 1.
2. Ram cup leather may be worn. See Instruction "3" of Section II.
3. Discharge ball in high pressure pump valve may not be seating properly. See Instruction "4" of Section 1.

### IV.

The Model X-10 is protected by a safety valve against damage through overloading. This valve is carefully set before leaving the factory and no further adjustment should be necessary. Any resetting in the field must be done by a Hein-Werner Official Service Station.